

OPERATION, INSTALLATION
& MAINTENANCE MANUAL

RF LEVEL TRANSMITTER

Series RFLT 900



LEVSEN CONTROLS & INSTRUMENTS

B-4, Aditya Complex, Block C-3, Yamuna Vihar,
DELHI – 110 053

CONTENTS

INTRODUCTION iii

- A. Application
- B. Configuration
- C. Working Principle

INSTALLATION vii

- A. Electronic Transmitter
- B. Probe Models
- C. Coaxial Cable

OPERATION xi

- A. Operation
- B. Calibration
- C. Maintenance

FACTORY ASSISTANCE xvi

ii

RADIO FREQUENCY (RF) LEVEL MONITOR
For granular materials & liquids

INTRODUCTION

A. Application

The instructions in this manual pertain to the RF Type Level Monitor. It is capable of monitoring the level of material at all times and provides an output analogous to the level of material.

The analogous level monitor utilizes an electronic transmitter and a sensing probe, provides Precision, Reliability independent of transit material, Suspended dust, Coating, material temperature, particle size etc., meaning thereby it can be used with wide variety of materials. Materials which are conductive, non-conductive, corrosive, solids, liquids, hot or cold which even tend to coat heavily on the sensing components or container inner shell can be accurately measured.

The output provided is analogous to the effective quantity of material available for use i.e. the material accumulated around the inner shell of the vessel (which is not effectively available for use) is ignored. Therefore for solid materials, effectively available quantity can not be compared directly by plumbing method.

C. Configuration

RF Bin Level Transmitter comprises of an Electronic Transmitter, a Sensing Probe and coaxial cable for the connection of the Electronic Transmitter to the Sensing Probe. Electronic Transmitter provides RF signals to the sensing probe at constant phase & frequency and measures the changes in the parameters provided by the sensing probe, which is mounted on the vessel containing material (to be measured).

The RF signal being measured changes with the change in media with particles of material in cohesive contact with the probe upto container shell (reference ground) which is processed to provide analogous and continuous output.

RF LEVEL TRANSMITTER (CONTINUOUS)

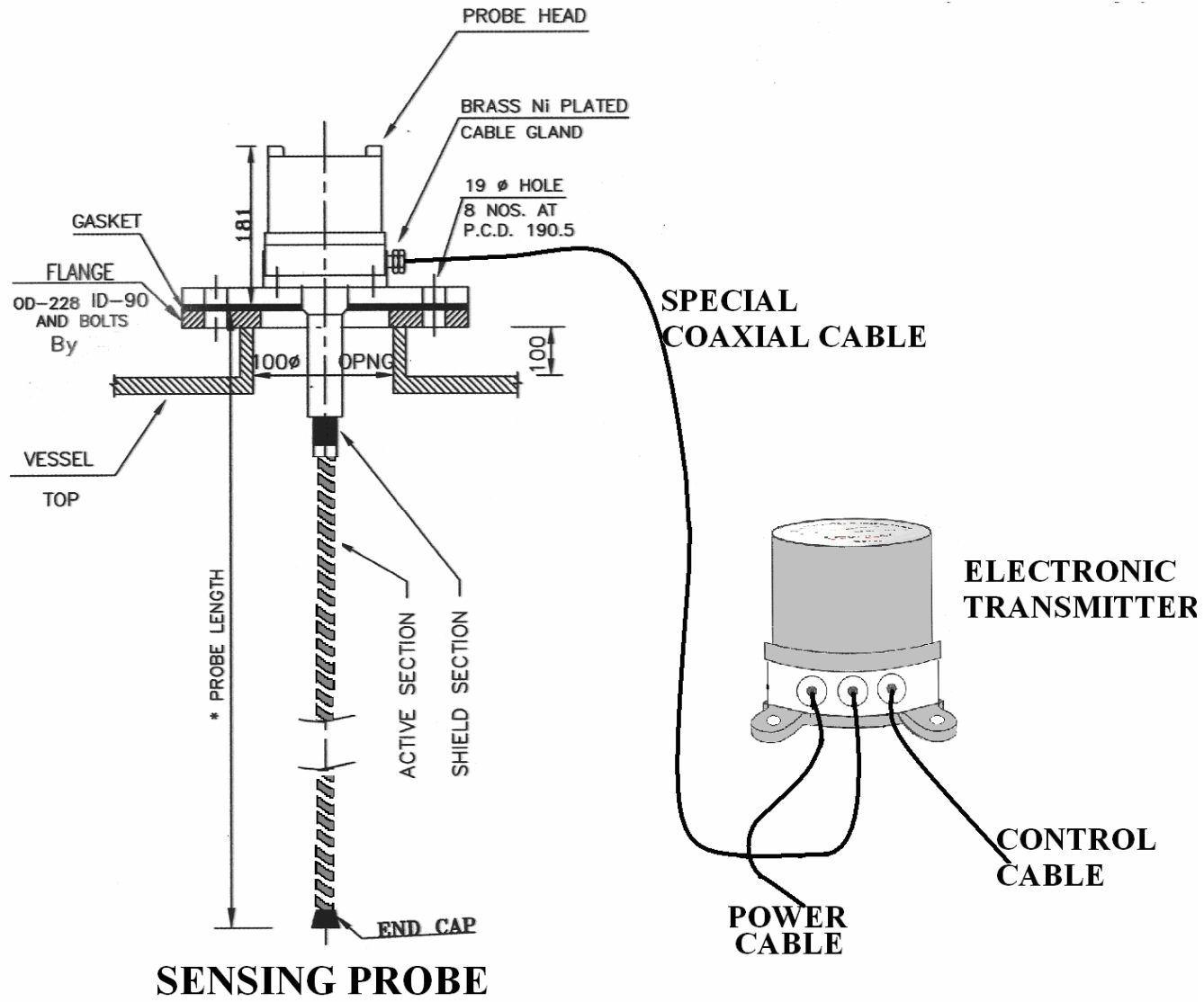

D. Working Principle

LEVSEN RF level Transmitter Series RFLT 900 works on Radio Frequency Principle. Independent but identical low power RF signals equal in frequency, phase, and amplitude and wave shape generated in Electronic Transmitter are provided to active and shield sections of the Sensing Probe whereas, the reference ground of electronics is connected to the vessel shell. The signal provided to the shield section is maintained constant by use of a compensating circuit in the Electronic Transmitter while the signal applied to the active section varies with the change of media to stored material having intraparticle cohesive contact from the probe to the vessel shell.

The suspended particles or material in transit do not have cohesive inter-particle contact and have no role in this RF principle of Level Sensing.

The variation in the active signal is compared with the constant shield signal. The difference is analyzed and converted into current parameter (output), analogous to the level of material available effectively for use in the bin/vessel.

PROBE MODELS

LEVSEN provides various models & types of sensing probes to suit customer requirements. Since the sensing probes do not contain any electronics, the electronic transmitter is identical for all the sensing probe.

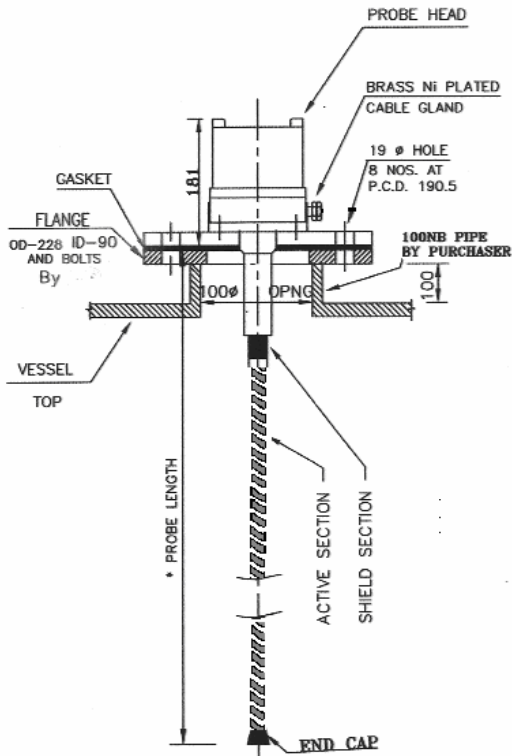

**SENSING PROBE
FLEXIBLE RFLT900-SP**

APPLICATION:

SOLID (POWDER & GRANULES) IN
PARTICLES SIZE FINEST TO MAX 50MM

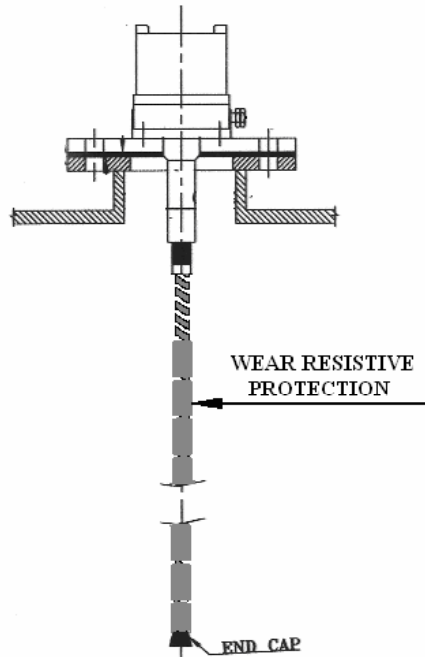

**SENSING PROBE
FLEXIBLE RFLT900-SPWR
(WEAR RESISTANT)**

APPLICATION:

EROSIVE MATERIAL GRANULER SOLID,
& LARGE PARTICLES UPTO 400MM

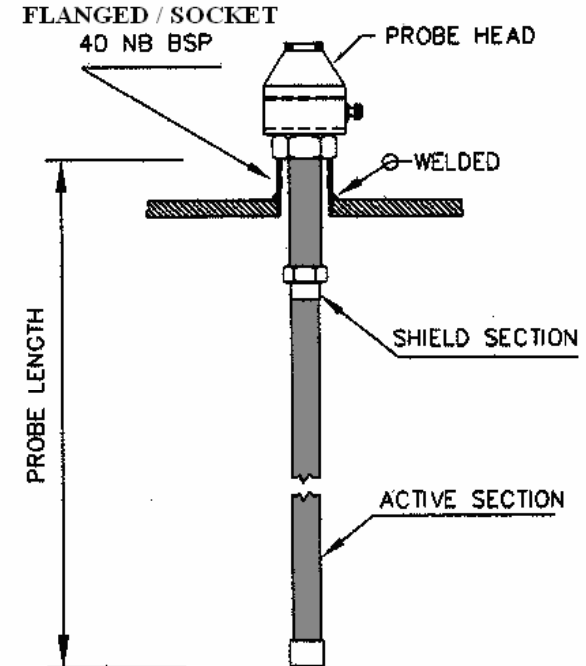

**SENSING PROBE
FLEXIBLE / RIGID RFLT900-IN
(INSULATED)**

APPLICATION:

LIQUID & CONDUCTIVE MATERIAL

INSTALLATION

A. *Receiving and Inspection*

To ensure proper receipt of materials, it is important to immediately check the contents of shipping containers. Contents should be compared against packing list to make sure that proper equipment have been received and that it has not been damaged during transit.

B. *Electronic Transmitt*

1. Location

The following should be considered while mounting the electronic transmitter:

Mounting	Mount on wall or other convenient structure at man- height for easy access to adjustment and free from obstruction.
Temperature	Be sure ambient temperature at the installation point does not exceed temperature limitation (-) 10°C to well below (+) 60°C.
Environment	No exposure to direct sunlight, rain or snow.
Vibration	If excess vibration in area is anticipated, consider alternate mounting area or place vibration absorbing material under the enclosure base.
Distance	Be certain cable distance from probe to electronic transmitter is minimum and does not exceed 25 mtrs. If, as per plant layout, the cable requirement is more than 25 mtrs, consult Levsen Controls and Instruments.

2. Cable Connections

In all case, care must be taken to ensure that cutout materials are not left in the enclosure and that proper cable fittings are utilized, like lugs, thimbles and glands etc. and must be properly supported and protected from any possibility of damage in future.

C. *Sensing Probe*

1. **Location (Top mounted probe)**

- i. Probe Length : must be less than the free vertical space for the probe.
- ii. Location : Nearest to filling point but not more than 1/5 of diameter/width of the vessel.
- iii. Preferred location : Between axes of fill point and outlet of the vessel.
- iv. Top mounted Probe must be located away from roof-supporting beams (as a rule of thumb). Horizontal distance should be more than the height of the beams.
- v. No possibility of shorting/fouling of probe with any metallic/grounded part.
- vi. Shield section must project freely inside the vessel.
- vii. Verify probe ground terminal shows continuity with vessel shell/vessel structure and earthing grid.

2. **Mounting**

Flange Connection

Provide suitable gasket and then insert probe gently in flanged nozzle provided on the vessel compatible with probe flange and provide bolts with nuts and washers.

Threaded Connection Insert probe in threaded coupling installed on container shell and thread.

The recommended mounting is determined by the vessel configuration and type of probe used. Consult Levsen Controls and Instruments for recommendation on your application.

D. Electrostatic Protector

Electrostatic protectors are provided for all applications where the possibility of electrostatic charge build-up on the probe is envisaged. This protector, a small board is mounted inside the Probe Head.

E. Wiring

1. Probe Cables

- i. Cable Levsen provides special screened coaxial cable for connection of electronic transmitter to probe. Use cable supplied/specified by Levsen only.
- ii. Termination Cables are cut to suit site condition. Total quantity of required length is supplied in random length.

Hook up of the probe cables requires connections of the three cable conductors. Centre Wire (CW) to “PR”, Middle Wire (MW) to shield “SH” and Top layer Drain Wire (DW) or a separate ground wire to Ground “G” at both electronic transmitter and sensing probe.

2. Power connections

Power connections (240/220/110/VAC, 50/60 Hz as specified) are made directly to the terminal block located inside the electronic transmitter. Due to the low power consumption (15W max.), light gauge wiring of size 1.0sqmm may be sufficient. However, consult the local Electrical regulations for exact wire gauge requirement.

3. Output connections

Analogous Output signal connections are made directly on the terminal blocks of transmitter through twisted pair screened cable for transmission for further use.

4. Setpoints

If opted, relay connections are provided directly on the terminal blocks located in the electronic transmitter. These relay contacts are rated 3 amp load at 220 VAC non-inductive. Output wiring should be compatible with the intended output load (less than 3 amps).

TERMINATION DRAWING

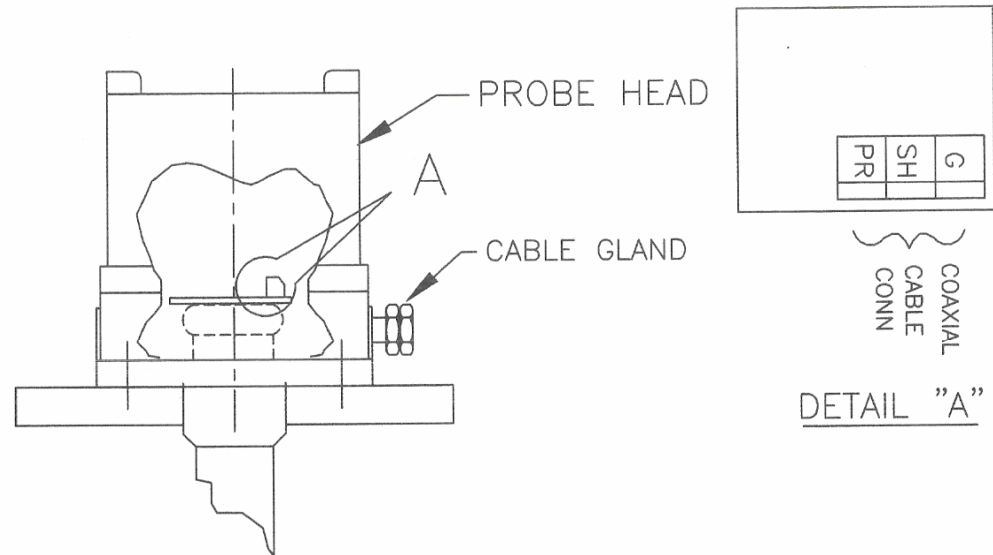
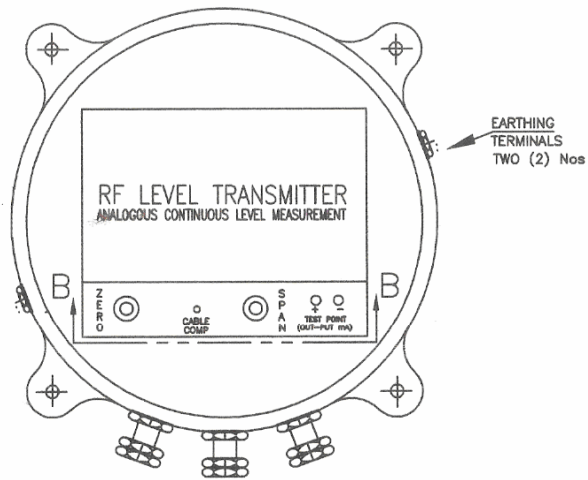

SENSING PROBE HEAD

ELECTRONIC TRANSMITTER

SUPPLY VOLTAGE			PROBE CONNECTION			OUT-PUT	
P	N	E	PR	SH	E	+	-
1	2	3	4	5	6	7	8
⊙	⊙	⊙	⊙	⊙	⊙	⊙	⊙

VIEW "BB"

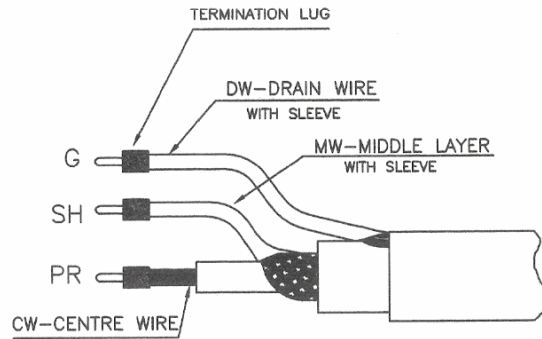

COAXIAL CABLE
FOR THE CONNECTION OF

X

NOTES:

1. RF SIGNAL CABLE FOR THE CONNECTION OF ELECTRONIC CONTROLLER TO SENSING PROBE SHALL BE COAXIAL CABLE.
2. SIGNAL CABLE LENGTH SHALL NOT EXCEED 25M UNLESS PRE-CONFIRMED By EIP
CONNECT CENTRE WIRE (CW) TO "PR"
MIDDLE WIRE (MW) TO "SH"
DRAIN WIRE (DW) TO "G"
3. USE SUITABLE CABLE LUGS, SLEEVE AND CABLE GLANDS AT BOTH ENDS
4. DO NOT PEEL "MW" MORE THAN 40mm (1.5")

OPERATION

A. *Adjustments*

- | | |
|--|--|
| <ul style="list-style-type: none">• Zero Adjustment• Span Adjustment• Cable compensation• Set Points (if opted) | <ul style="list-style-type: none">Adjustable to suit site conditionsAdjustable to suit site conditionsAdjustable at siteAdjustable to suit plant requirements |
|--|--|

B. *Start-Up*

Before start-up, verify the following:

- All wiring connections have been made properly with proper fittings
- The power supply voltage to be applied as specified and mentioned at the Terminals.
- Shield section of sensing probe is projected (inserted) inside the vessel freely at least 25mm (1”) i.e. no grounded part covers the shield section very close to it.
- Length of the probes is less than the free internal height of the vessel i.e. it is not likely to touch any part of the vessel body or any other equipment or obstacle inside the vessel which may result in short-circuiting with the ground.
- Probe (if flexible) is mounted from the top of the vessel vertically down and is located as close as possible to the axis of the outlet/s of the vessel or between axes of inlet/s and outlet/s and at maximum possible distance from the side walls of the vessel.
- For connection of sensing probe to electronic transmitter only coaxial cable is used as supplied/specified and connections as explained in II.E.1.

C. Calibration

Calibration can be accomplished using the following procedure :

For maximum accuracy, all calibration adjustments should be made with the material to be sensed at normal operating conditions.

C.I. TRANSMITTER OUTPUT (ANALOGOUS)

1. Make normal connections and verify. Connect specified power supply voltage and connect an Ammeter of range 0-25mA at test-points with output connected to load or shorted with the help of a temporary jumper.
2. **Cable Compensation:** Put the ground Switch (toggle Switch) in “OFF” position given on the side of Electronic Transmitter and adjust “Zero” knob so that ammeter connected at output /test-points reads 10mA (approximately), adjust cable compensation knob clockwise/anticlockwise to attain the *least* value of output.
3. **Zero adjustment:** With the ground Switch still in “OFF” position , adjust “Zero” to obtain an output 4 mA.

Note that the Transmitter is provided with zero-locking. i.e. out-put will not cross below 4 mA even if zero adjustment is reduced below 4 mA. Therefore initial adjustments be done keeping output more than 4mA which, finally be adjusted back after “SPAN” adjustment.

4. **Span adjustment :** Connect “G” at the Electronic Transmitter end. wait for material level built-up to more than 50% level and then removal of more than 25%, so that the probe is firmly embedded in the material.

Find the present approximate value of average level of material in the Bin by Manual/trial methods, adjust “SPAN” to obtain out-put proportional to present desired value, readjust “ZERO” to reduce out-put by 0.25mA.

5. Verification :

With material collection/removal in progress, observe output mA at Electronic Transmitter with material level/quantity variation (Manually) periodically and note the observations.

6. Graphical Verification :

Plot a trend graph of mA vs Level (in metres) from above observations (a straight line curve). Also draw a desired IDEAL straight line curve at the same scale. Extend the curve to mA line.

Measure the gap between Ideal Curve and the actual curve at mA line.

Reduce/increase the output by “ZERO” adjustment as per 3.

Adjust the “SPAN” to achieve present desired output (mA) value.

7. For satisfaction, verify 5. If required, repeat 6.

Calibration is now complete for the transmitter analogous output.

C.II. DIGITAL DISPLAY (IF OPTED)

Digital display (if opted) is factory calibrated for specified range of LEVEL. If desired to adjust to any value other than specified to suit actual plant/site requirement, adopt the following procedure :

Adjust trim-pots on display PCB marked “Z” and “S” to obtain desired display (i.e. at output 4mA, set display as 0.00 and at output 20mA, set display at full range i.e. 100% desired level).

C.III. SET-POINT ADJUSTMENT (IF OPTED)

Press respective button to display present set-point value. To adjust, keep the respective push-button pressed and adjust respective trim-pot to obtain desired set-point value. Release the push button. Similarly adjust the next set-point.

MAINTENANCE

a. Normal

Radio Frequency based Level Transmitters are designed to provide years of maintenance-free service. This is ensured by use of solid-state circuit throughout and no moving parts are used. However in the event of any trouble, follow the procedure given below:

b. Troubleshooting

Troubleshooting procedure is explained below considering level transmitter of output 4-20mA. For output specification other than 4-20mA, values may be changed accordingly.

1. Check supply voltage at supply terminals (1&2) by a voltmeter. If this is correct, proceed to B2.
2. Verify all connections are normal, connect specified supply voltage as mentioned on the terminals and also connect an ammeter of range more than 20mA, to the output test-points located on the electronic transmitter with output terminals connected to load or shorted through a jumper or directly at output terminals with load/shorting jumper disconnected.

Check the following:

- a. Ammeter should read 4mA or above. If yes, proceed to B2b. If no, check the fuse provided in the electronic transmitter chassis. If fuse is OK, check the ammeter being used. If both the fuse and ammeter are OK, verify once again the supply voltage at the terminals of the electronic transmitter. If supply voltage is also OK, and still output is not as required, proceed to IV C.
- b. Adjust “ZERO” to obtain output more than 5mA but less than 15mA. Open the Probe housing cover, touch the flange inside the housing (active section) firmly by one hand and the earthing mat or nearby grounded structure by the other hand. The output at ammeter should vary. If yes, verify calibration as explained in III C, if not, then proceed to B2c.
- c. Disconnect cable at probe end, touch center wire (cw) firmly by one hand and grounded nearby structure or earthing mat by other hand firmly, output must vary. If yes, change the electrostatic protector, reconnect the cable and recalibrate as in III C. If no, proceed to B3.

3. Electronic Transmitter

- a. Disconnect the probe coaxial cable connections (centre wire, shield wire and ground wire) at the electronic transmitter. Leave power connected.
- b. With probe cable disconnected at electronic transmitter, connect a voltmeter which is set on a low DC voltage range (approx) 20Vdc range.
- c. Adjust "ZERO" to obtain more than 5mA.
- d. Place a capacitor or a resistor of any (low) value (if none of these is available then use your fingers) at the "PR" and "G" terminals firmly and check that the output varies. Now remove the capacitor/resistor/fingers from the terminals.
- e. With specified input power applied to the electronic transmitter, measure the following voltage at transmitter terminals :
 - i) Probe to groundVDC
 - ii) Shield to groundVDCThe above values should read approx. 3 VDC. Value at (i) should read within ± 5 to 10% of value at (ii).
- f. If the output varies with the "d" and values obtained in "e" are as they should be, then the Electronic Transmitter is OK, proceed to IV B2.
- g. If the output reading does not vary with "d" and values in "e" are not as they should be, then there may be a fault in the electronic transmitter.

FACTORY ASSISTANCE

For any queries, you may kindly contact our Technical Experts at the following address :

LEVSEN CONTROLS & INSTRUMENTS

B-4, ADITYA COMPLEX,
BLOCK C-3, YAMUNA VIHAR,
DELHI – 110 053

Ph.No. : 011-22914561 – 62

Fax No. : 011-22914562

e-mail : info@levsencontrols.com
levsencontrols@yahoo.co.in
levsencontrols@gmail.com

Website: www.levsencontrols.com